

# ROBUS®

## COSMIC 300W LED FLOOD LIGHT, IP65, BLACK, 4000K RCM30040-04

**PLEASE READ INSTRUCTION BEFORE COMMENCING INSTALLATION AND RETAIN FOR FUTURE REFERENCES. ! Electrical products can cause death or injury, or damage to property. The Installation must be carried out by a qualified electrician.**

**Note:**

The luminaire must be disconnected before carrying out any insulation resistance testing. Product technical information and specification may change over time without prior notification. For the latest technical information please visit our web site [www.robus.com.au](http://www.robus.com.au) and [www.robusled.co.nz](http://www.robusled.co.nz)

-20°C < Ta < +40°C, 220-240V ~ 50/60Hz, Class I, IP65  
Luminaire is non-dimmable

### Installation

1. Ensure mains supply is switched off before commencing work.
2. Select suitable location for luminaire.
3. Mark wall with appropriate fixing positions. Before drilling, ensure that the hole does not impinge on pipe work, cables or other building services.
4. Attach luminaire and fix bracket by tighten screws, then adjust to desired angle. Ensure that it is secure.
5. The luminaire is supplied with 1m of rubber cable. Using suitable IP rated enclosure terminate Brown (Live), Blue (Neutral) and Green/Yellow (Earth) to switch supply.
6. This product has no user serviceable parts. If any part is damaged, disconnect from mains and discontinue use.

Note: No "fixings screws provided", please use appropriate fixing screws.

Projection Distance:	17.5m
Max Projection Area:	33m
Mounting Height:	12.5-18m

**The Installation must be carried out by a qualified electrician**

LED Group Australia Pty Limited  
Suite B, 2 Pittwin Road  
Capalaba  
Queensland 4157  
Australia  
Tel: 07 3890 5444  
Fax: 07 3890 4777  
Email: [purchases@robus.com](mailto:purchases@robus.com)  
Website: [www.robus.com.au](http://www.robus.com.au)

LED Group  
Crowe Horwath  
72 Trafalgar Street  
NELSON 7010  
New Zealand  
Tel: +64 3668 5285  
Email: [nz\\_purchases@robus.com](mailto:nz_purchases@robus.com)  
Website: [www.robusled.co.nz](http://www.robusled.co.nz)



Warning: Do not stare at the operating light source

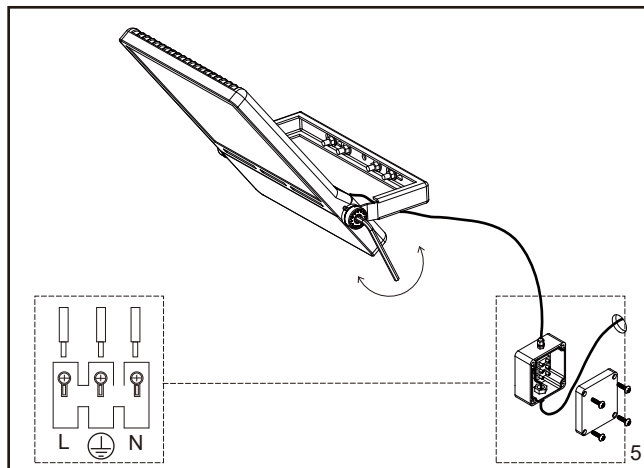
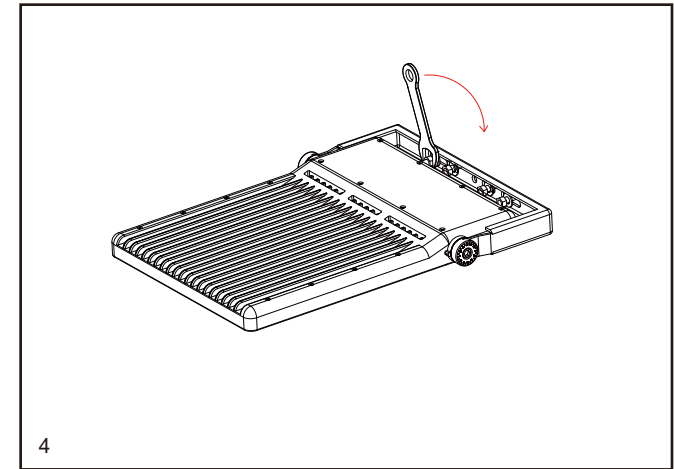
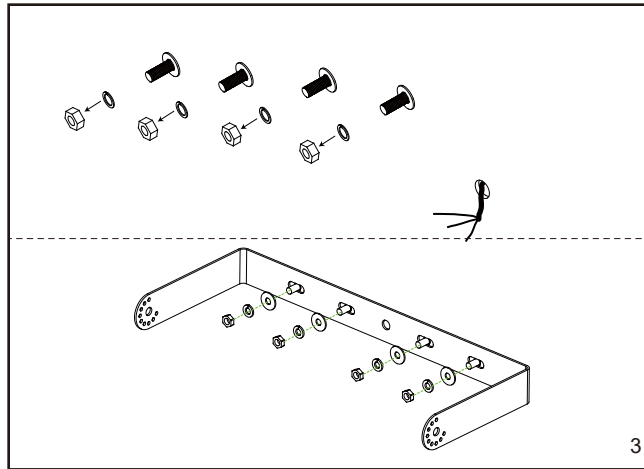
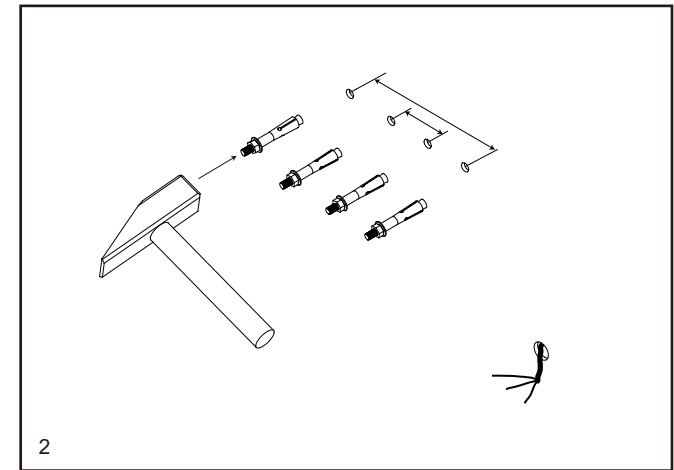
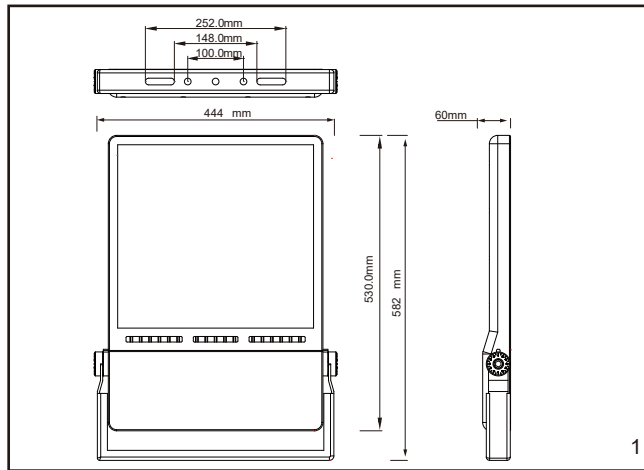

# ROBUS®

## COSMIC 300W LED FLOOD LIGHT, SPIGOT ACCESSORY, BLACK

### RCMS-04

PLEASE READ INSTRUCTION BEFORE COMMENCING INSTALLATION AND RETAIN FOR FUTURE REFERENCES.

! Electrical products can cause death or injury, or damage to property. If in any doubt about the installation or use of this product, consult a competent electrician

**Note:**

Product technical information and specification may change over time without prior notification. For the latest technical information please visit our web site [www.robus.com.au](http://www.robus.com.au) or [robused.co.nz](http://robused.co.nz)

### Installation

1. Select suitable location for luminaire. Ensure spigot is  $\varnothing 50\text{-}60\text{mm}$  in diameter
2. Fix the spigot accessory onto the bracket as per figure 2. Adjust to desired angle. Ensure it is secure
3. Attach luminaire with accessory onto the  $\varnothing 50\text{-}60\text{mm}$  spigot and tighten screws as per figure 3 or 4.
4. Adjust the Luminaire to desired angle and then tighten bolts as per figure 5. Ensure that it is secure.

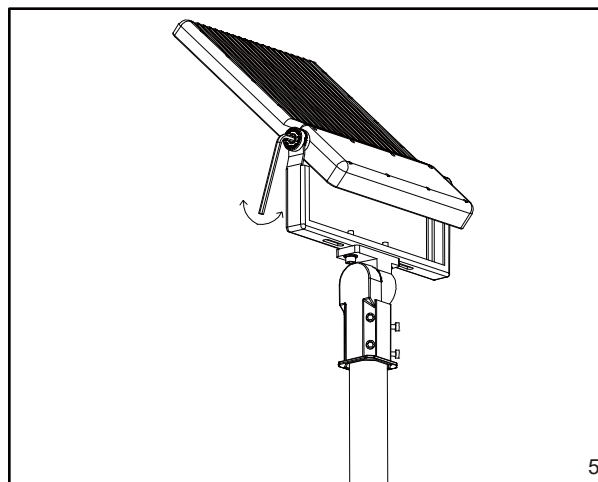
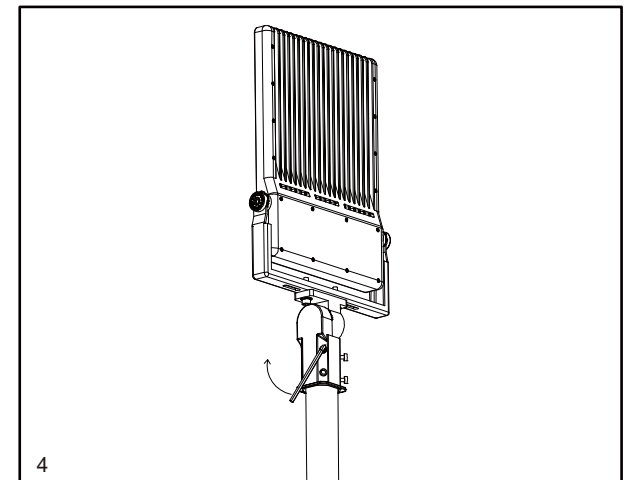
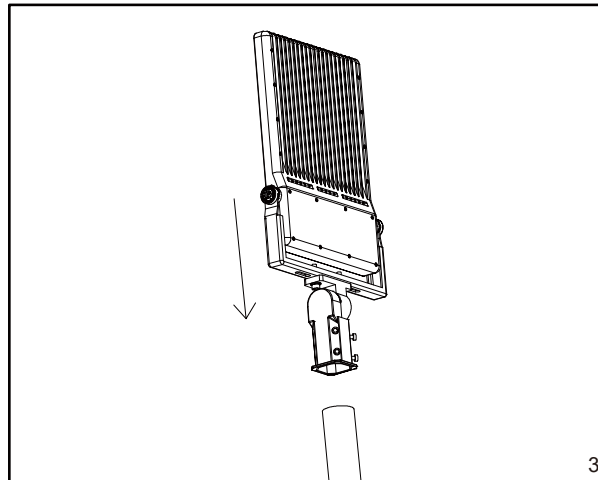
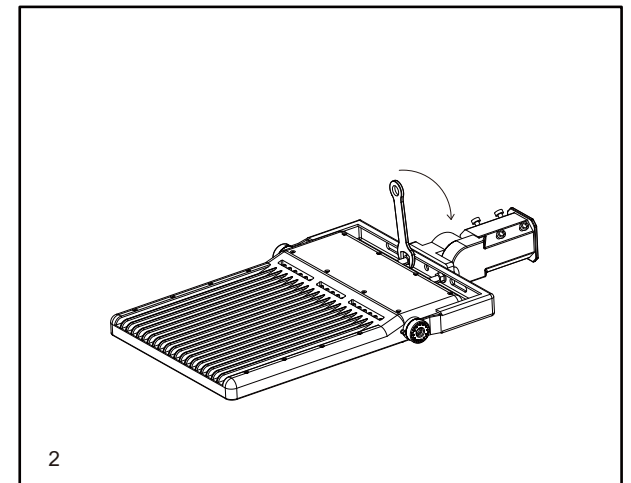
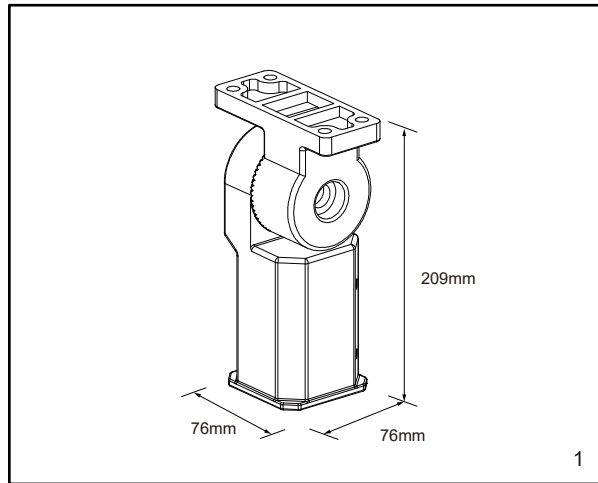

The Installation must be carried out by a qualified electrician

LED Group Australia Pty Limited  
Suite B, 2 Pittwin Road  
Capalaba  
Queensland 4157  
Australia  
Tel: 07 3890 5444  
Fax: 07 3890 4777  
Email: [purchases@robus.com](mailto:purchases@robus.com)  
Website: [www.robus.com.au](http://www.robus.com.au)

LED Group  
Crowe Horwath  
72 Trafalgar Street  
NELSON 7010  
New Zealand  
Tel: +64 3668 5285  
Email: [nz\\_purchases@robus.com](mailto:nz_purchases@robus.com)  
Website: [www.robused.co.nz](http://www.robused.co.nz)

